

CUSCINETTI A SFERA

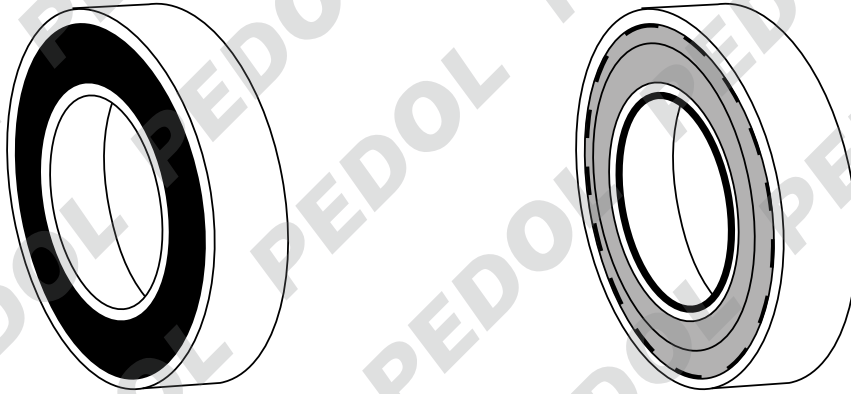

Codice	Descrizione	Codice	Descrizione	Codice	Descrizione	Codice	Descrizione
33938	607-2RS	33928	6005-2Z	33978	6208-2Z	34050	6308-2RS
33939	607-2Z	33929	6006-2RS	33981	6209-2RS	34051	6308-2Z
33941	608-2RS	33930	6006-2Z	33982	6209-2Z	34053	6309-2RS
33942	608-2Z	33932	6007-2RS	33985	6210-2RS	34054	6309-2Z
33943	609-2RS	33933	6007-2Z	33986	6210-2Z	34056	6310-2RS
33944	609-2Z	33934	6008-2RS	49866	6211-2RS	34057	6310-2Z
34016	624-2Z	33935	6008-2Z	33989	6211-2Z	34059	6311-2RS
34017	625-2Z	33936	6009-2RS	33991	6212-2RS	34060	6311-2Z
34018	626-2RS	33937	6010-2RS	85890	6212-2Z	34062	6312-2RS
34019	626-2Z	33947	6200-2RS	33995	6213-2Z	34063	6312-2Z
34020	627-2RS	33948	6200-2Z	34025	6300-2RS	34065	6313-2RS
34021	627-2Z	33951	6201-2RS	34026	6300-2Z	34066	6313-2Z
34022	629-2RS	33952	6201-2Z	34029	6301-2RS	81394	6314-2RS
34023	629-2Z	33955	6202-2RS	34030	6301-2Z		
34068	635-2Z	33956	6202-2Z	34032	6302-2RS		
33908	6000-2RS	33959	6203-2RS	34033	6302-2Z		
33909	6000-2Z	33960	6203-2Z	34035	6303-2RS		
33912	6001-2RS	33963	6204-2RS	34036	6303-2Z		
33913	6001-2Z	33964	6204-2Z	34038	6304-2RS		
33916	6002-2RS	33967	6205-2RS	34039	6304-2Z		
33917	6002-2Z	33968	6205-2Z	34041	6305-2RS		
33920	6003-2RS	33971	6206-2RS	34042	6305-2Z		
33921	6003-2Z	33972	6206-2Z	34044	6306-2RS		
33924	6004-2RS	33974	6207-2RS	34045	6306-2Z		
33925	6004-2Z	33975	6207-2Z	34047	6307-2RS		
33927	6005-2RS	33977	6208-2RS	34048	6307-2Z		

REVISIONATI	
Codice	Descrizione
14438	6004-2RS E
14440	6005-2RS E
14441	6009-2Z E
14442	6201-2Z E
14439	6204-2RS E
14444	6205-2RS E
14437	6303-2RS E
14446	6304-2RS E
14443	6304-2Z E

CUSCINETTI ENCODER



A



B

Codice	Pos.	Applicazione
66267	B	Bt-Toyota
68221	A	Jungheinrich
68242	B	Jungheinrich

CUSCINETTI A RULLINI

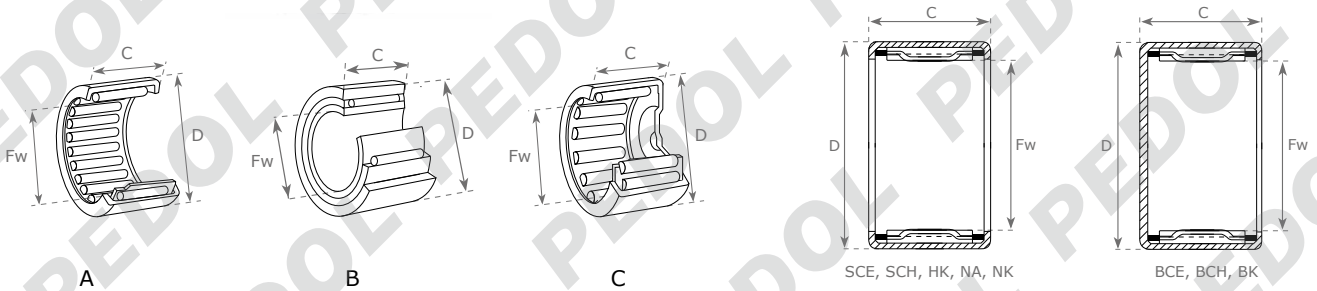

A

B

C

SCE, SCH, HK, NA, NK

BCE, BCH, BK

Codice	Sigla	Pos.	Mis. int. (mm) Fw	Mis. est. (mm) D	Mis. spess.(mm) C
65079	HK 1014	A	16	22	14
63273	HK 2216	A	22	28	16
51126	NK 20/20A	A	20	28	20
51171	HK 2220	A	22	28	20
65707	HK 2526B	A	25	32	26
65090	RNA 4905	A	30	42	17
18505	BK 3026	C	30	37	26
18508	BK 3038	C	30	37	38
16898	NA 2030	B	30	38,3	22
15777	HK 3520	A	35	42	20
16215	NK 35/30	A	35	45	30
16897	NA 2035	B	35	58	22
51129	NABi 22040 R6/NANa J9419 SG7	B	40	62	30

CUSCINETTI A RULLI CONICI

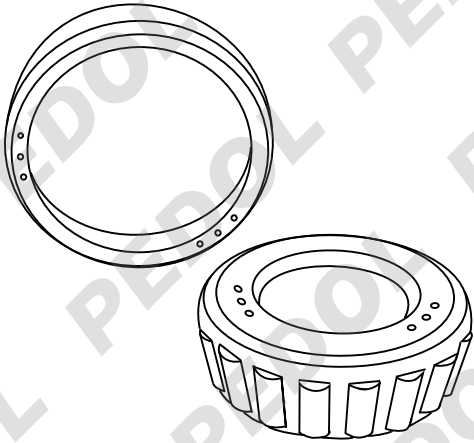

Codice	Mis. int. (mm)	Mis. est. (mm)	Mis. spess. (mm)
60738	25	47	15
16243	25	52	16,25
63284	25	62	18,25
63283	25	62	25,25
16217	29	50,29	14,22
16997	30	62	17,25
16218	31,75	59,13	15,88
66769	31,75	68,26	22,22
18784	33,33	73,02	29,37
16394	33,34	68,26	22,23
16073	34,98	59,97	15,87
16018	34,99	59,97	18,5
65056	35	62	18
66125	35	72	18,25
63328	35	72	24,25
68176	30,16	64,3	22
15918	38,1	65,09	18,03
16002	40	68	19
65055	41	68	18
62536	36,5	76,2	29,5
16998	40	80	19,75
19071	41,28	73,43	19,56
51039	50	80	20
16335	50	80	22
18641	50	82	21,5
18502	55	90	23
16718	65	100	23
17066	75	105	20
65027	75	115	25
19043	84,4	130,2	31,2
66633	34,93	65,09	19,24
66683	45	80	26
66634	41,28	73,43	19,56
65056	35	62	18

REGGISPINTA A RULLI



Codice	Mis. int. (mm) d	Mis. est. (mm) D	Mis. spess. (mm) T
62543	25	42	11
15874	30,5	55	11,5
16144	30,5	56	16
59500	30	65	15
59505	35,3	65	15
62735	40	66	19,5
59501	40	72,5	21,5
17079	51	75	16

REGGISPINTA A SFERE

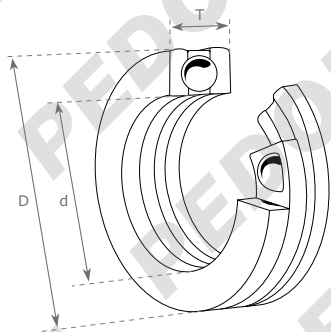

Codice	Mis. int. (mm) d	Mis. est. (mm) D	Mis. spess. (mm) T
16799	25	47	15
63275	30	52	16
62544	30	60	21
16899	35	62	18
51008	60	85	17
60737	70	95	18
60746	90	120	22

SNODI SFERICI

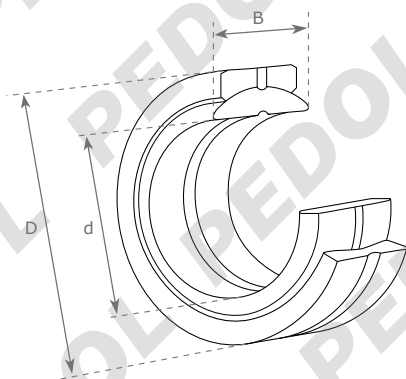

Codice	Sigla	Mis. int. (mm) d	Mis. est. (mm) D	Mis. spess. (mm) B
15705	GE 17 ES	17	30	10-14
65123	BLRB 366432	20	30	14
65676	GEGW 17 ES 2RS	17	35	12-20
62725	GE 20 ES 2RS	20	35	12-16
65521		20	42	16-24
14435	GEG 20 ES 2RS	20	42	16-25
15774	GE 25 ES 2RS	25	42	16-20
18693	GE 25 ES	25	42	16-20
65122	BLRB 366711	30	42	16-17
15772	GE 30 ES	30	47	18-22
65512	GE 35 ES	35	55	20-25
16782	GE 40 ES	40	62	22-28
66591	E45 2RS	45	68	25-27
65119	GE 45 ES	45	68	25-32
65476	GE 45 ES 2RS	45	68	25-32
65977	GE 50 ES 2RS	50	75	28-35
65120	GE 60 ES	60	90	36-44

PEDOL

www.pedol.com

Fratelli Pedol s.p.a

Sede legale, produzione cabine, marmitte e paraurti

Via Fabbri, 10 - Z.I. Campidui
31015 Conegliano (Treviso)
Tel. +39 0438 450952
Fax +39 0438 450979

info@pedol.com

Sede commerciale Conegliano

Via dell'Industria, 29
31015 Conegliano (Treviso)

Ricambi carrelli elevatori

Tel. +39 0438 411884
Fax +39 0438 411015

Ricambi auto/ elettromeccanica

Tel. +39 0438 32941
Fax +39 0438 411015

Sede commerciale Bellusco

Via Ornago, 27
20040 Bellusco (Milano)

Ricambi carrelli elevatori

Tel. +39 039 6883373
Fax +39 039 6202105